

A Laser-based, In-line Chlorine Dioxide Concentration Sensor

Glukhovskoy A., Schnebeck T., Holz S., Fischer E., Wurz M.C.

Abstract

In this work we present the development of an in-line concentration sensor purposed to determine the chlorine dioxide concentration dissolved in tap and industrial water. This disinfectant is widely used in Europe. Using direct photometry, the agent's concentration is assumed to be directly proportional to its absorbance, in correspondence with the Beer-Lambert Law. The sensor is mounted in a water pipe segment enclosing a photometric flow-through cuvette sealed with a pressurized window. The sensor is designed to feature a concentration resolution of 50 ppb and consequently, the required contrast should be maximized. On that account, the effective optical path is lengthened through multiple reflections of a probing laser beam within the cuvette. Since the analyzed water always contains scattering particles of mineral, organic, or gaseous origin the transmitted signal is undesirably attenuated. In order to compensate for this attenuation, the dual wavelength light source subassembly is developed. The laser diodes demonstrate a noticeable dependence on the emitted wavelength of the crystal temperature. In order to eliminate this uncertainty, the diode thermal stabilization modules were used. Due to the modular construction of the sensor, the fully adjusted optical subassembly can be easily replaced without dismounting the pipe system. Several sensors were built for field testing. Within the tests, the sensors demonstrated properties on par with existing industrial sensors based on other measurement principles (DPD colorimetric and amperometric). Additionally, this sensor is inertia-free, requires no disposable parts and requires only low maintenance. The combination of the measurement principle, the sensor construction, and the technical realization may serve well for many other applications, including the analysis of chemical composition within the pipelines, containers, or reactors, as well as gas analysis and others.

Keywords — water; water analysis; environmental analysis; chlorine dioxide; photometry; absorbance; multipathing

1 INTRODUCTION

The population growth, urbanization, industrialization, and climate change have induced demands for freshwater resources [1].

Only a small fraction of the available freshwater is safe to drink when untreated. The importance of clean water has been demonstrated in Northern Wisconsin: During the rapid installation of water treatment stations (2011-2016) the number of gastrointestinal illness incidences has largely decreased (av. 82%) [2]. The freshwater treatment removes contaminants of three major types: 1 liquid and solid particles, causing turbidity; 2 Inorganic contaminants including dissolved salts and gases, and 3 organic contaminants, and pathogens of various types. Treatments include various methods e.g.: aeration, reverse osmosis, sedimentation, filtration, and disinfection.

One of the common disinfectants widely used in Europe is chlorine dioxide [3]. Chlorine dioxide (ClO_2) is superior to other oxidizing agents, (e.g. chlorine), in many ways: ClO_2 is less corrosive and in most circumstances more effective against waterborne pathogens including viruses, bacteria, spores, and cysts. ClO_2 has been proven to suppress and prevent biofouling in a pipe system. ClO_2 is a yellowish gas at room temperature with a chlorine-like odor. Chlorine dioxide readily dissolves in water but unlike chlorine, ClO_2 does not undergo a corresponding chemical reaction [4]. The aqueous chlorine dioxide has a wide characteristic absorption spectrum in the UV/Visible region in the range of 240-460 nm, whereby the maximum absorption is approx. 360 – 370 nm, which can be detected in direct visible light photometry.

According to the DIN 12671:2014, tap water may contain 0.05-0.2 mg/l chlorine dioxide although during disinfection it may reach up to 0.4 mg/l. In order to control the amount of ClO_2 in treated water, a reliable sensor is required. Among the others, there are two most used sensor types in the industry: DPD colorimetric method (which stands for N,N-diethyl-p-phenylenediamine) and the amperometric method utilizing selectively permeable membrane[5]. However, the DPD requires a constant supply of indicator agent and require rather complex

automated sample preparation subsystem. Whereas the membrane has to be regularly replaced for the amperometric method. Both these methods have relatively long reaction time (in a range of tens of seconds to minutes) and are expensive but well suited for the large water treatment facilities. Nonetheless, there are several applications which require a fast, cost-effective and low-maintenance sensor.

The systems developed and described herein, may be used as a water purification system for a farm, for example, stand-alone hotels or a small town. The system could also be placed in industrial water purification equipment. However, we believe in a substantial application within the food industry, where microorganisms are often key elements in food production processes, such as fermentation in breweries or souring in milk processing plants. Disinfectants are used to clean the technological vessels e.g. pipelines, reactors, and tools. It is vital to know if the water contains any remaining disinfecting agent, which could interfere with the microorganisms, therefore slowing down the bioreaction and reducing the production rate and efficiency.

2 THE MEASUREMENT PRINCIPLE

We consider the direct photometry technique as a promising alternative measurement principle, which suits the sensor properties requirements. Direct photometry offers the advantage, that there is no need for any additional disposable chemical agents or complex automated sample preparation unit. On the other hand, neither electrodes nor semipermeable membranes required. The water exchange may become as fast as the normal flow rate in the supplying pipe system yet providing the instantaneous response to the ClO₂ concentration change.

The core of the sensor consists of a measurement cavity holding the analyte, a light source, and a photodetector.

The characteristic absorbance of a substance in a photometric cell is described with the Beer-Lambert-Bouguer law:

$$A = -\log_{10} \left(\frac{I_t}{I_0} \right) = \varepsilon c l,$$

where I_0 and I_t are the corresponding intensities of the incident light and the light transmitted through the analyte; ε is the attenuation (or extinction) coefficient, which is analyte-specific; c denotes the concentration of the ClO₂ in water; l is the optical path; and A is the analyte's absorbance.

The analytical quantitative method we use is called a standard addition. The incident and

transmitted light are measured with respective photodiodes. The resulting absorbance is then calibrated for the baseline with a water sample that does not contain any ClO₂. Water containing a known amount of ClO₂ (quantified using the amperometric method as well as the standard industrial method of colorimetric DPD detection according to DIN 7393) is circulating through the flow cell. By adding a controlled amount of concentrated ClO₂ solution to the circulating water, the common chlorine dioxide concentration is gradually changed. This allows the transmittance of the cell to be measured in relation to the defined and controlled ClO₂ concentration.

3 SENSOR DESIGN

Figure 1 depicts a cross sectional view of the sensor with a violet line representing the probing light beam. The core of the sensor is the measurement cavity equipped with pipe fittings and a slot for the optical inset. The inset consists of a lid sealed with O-rings, a pressurized window and a mirror system. The optical assembly is attached to the optical inset and includes the module holders and the beam conditioning elements Such as beam splitter, multi-stage apertures, etc. The unified cylindrical modules are either laser diodes with collimating optics or photodiodes.

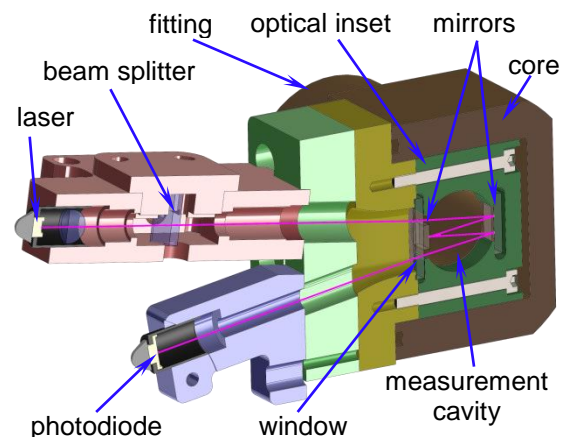

Figure 1 Cross-section of the sensor

4 CHALLENGES AND SOLUTIONS

4.1 CELL LENGTH

Since the extinction coefficient of the ClO₂ is constant for a given wavelength the only option to extend the measurement range towards lower concentrations and to improve the accuracy of the sensor is to refine the contrast of the

optical signal. We chose to lengthen the optical path l as a feasible option. In order to keep the sensor compact and to simplify its maintenance, we chose to create multiple passages of the probing light through the measuring volume. It experiences three reflections resulting in a total optical path of 80 mm.

4.2 TURBIDITY

Despite the effort of water purification, water can and will contain microscopically small mineral particles and micro gas bubbles suspended in a water stream. These particles and bubbles will distort and scatter the probing light. For a low scattering, the contribution can be expressed as an additional term absorbance, bl :

$$A = -\log_{10} \left(\frac{I_t}{I_0} \right) = \varepsilon c l + b l.$$

The term is independent of the ClO_2 concentration. Within the first approximation sequence we neglect the dispersion of light scattering by particles for low wavelength increment, $\Delta\lambda$. Since the ClO_2 extinction coefficient at the first wavelength is more than 8-fold higher than at the second this assumption is valid. Utilizing such dual wavelength measurement, the scattering contribution b can be subtracted. The composite light source consists of two laser diodes with collimating optics, a beam coupler, and beam shaping apertures. The absorption measurement cycle consists of two subsequent light pulses for each of the wavelengths and the delay between them for subtraction of the dark signal. The dark signal is amplified dark current of the photodiodes, bias of the transimpedance amplifier. The ambient illumination for example, can also contribute to the amount of dark signal.

4.3 WAVELENGTH STABILITY

Since the wavelength of a readily available laser diode does not match the maximum of the absorption spectrum of ClO_2 , any deviation of its emitting wavelength leads to a significant change in its extinction coefficient. This change will introduce a constant error to the concentration readings.

The common and major source of the wavelength deviation of a laser diode is the temperature of its active region. To keep the temperature of the laser diode consistent we developed a proportional–integral–derivative (PID) regulated thermal stabilization module (see Fig.2).



Figure 2 Thermal stabilization module

4.4 MAINTENANCE

Although the direct photometric measurement principle helps to reduce the maintenance, it is advantageous to eliminate the need to dismantle the sensor. The inset with the optical assembly can be easily extracted from the main body of the sensor and temporarily replaced with a lid or a replacement assembly. The optical surfaces of the extracted assembly can then be easily inspected and cleaned and when necessary – adjusted and recalibrated, as shown in Figure 3.

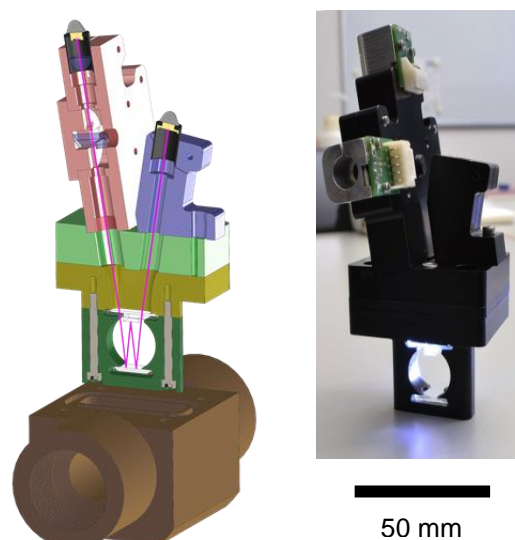

Figure 3 The sensor assembly dismantled from its core

The control unit of the sensor was developed and manufactured by TEWISS GmbH. The main board of the unit integrates power protection and multi-channel supply circuitry, adjusta-

ble transimpedance amplifiers, heating elements controllers, dual channel 16-bit ADC circuit, laser driver modules, real-time clock and is driven by a microcontroller and a single board computer (SBC), Raspberry PI. The SBC is responsible for communication, logging, and runs a web server.

5 THE RESULTS

The test measurement and calibration were carried out at the research facility of Dr. Küke GmbH (Mellendorf, Germany). Figure 4 shows a short exemplary segment of a test session wherein the sensors were exposed to the analyte with various predefined ClO_2 concentrations for extended periods of time which were separated by the pipeline purging stages. The ClO_2 concentrations were monitored by the sensor prototype and controlled with DPD, amperometrically, and manually by means of analytic chemistry. The tests demonstrate a great potential of the realization of the direct in-line photometric concept.

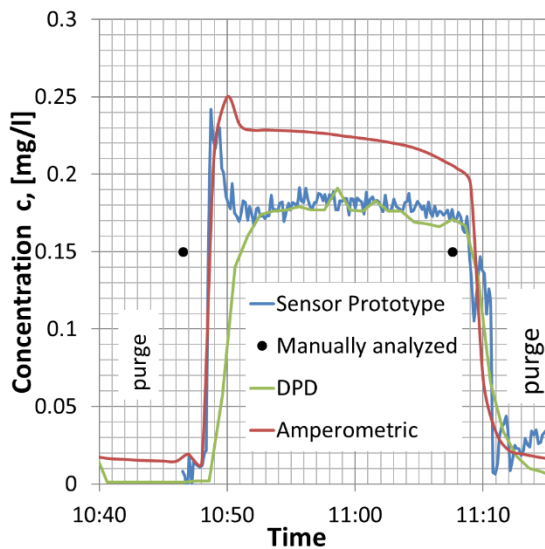

Figure 4 An exemplary segment of a measurement session.

References

- [1] "Unsustainable Growth And Increasing Global Water Demand," 2014.
- [2] C. K. Uejio, M. Christenson, C. Moran, and M. Gorelick, "Drinking-water treatment, climate change, and childhood gastrointestinal illness projections for northern Wisconsin (USA) communities drinking untreated

groundwater," *Hydrogeol. J.*, vol. 25, no. 4, pp. 969–979, Jun. 2017.

- [3] S. D. Richardson, M. J. Plewa, E. D. Wagner, R. Schoeny, and D. M. Demarini, "Occurrence, genotoxicity, and carcinogenicity of regulated and emerging disinfection by-products in drinking water: a review and roadmap for research.," *Mutat. Res.*, vol. 636, no. 1–3, pp. 178–242, Jan. 2007.
- [4] G. C. White and Black & Veatch., *White's handbook of chlorination and alternative disinfectants*. Wiley, 2010.
- [5] Z. Körtvélyesi, "Analytical Methods for the Measurement of Chlorine Dioxide and Related Oxychlorine Species in Aqueous Solution," Miami University, 2004.

Author: Glukhovskoy, Anatoly

University: Leibniz Universität Hannover

Department: IMPT

Author: Schnebeck, Thorsten

Company: TEWISS GmbH

Author: Holz, Stephanie

Company: Dr. Küke GmbH

Author: Fischer, Eike

University: Leibniz Universität Hannover

Department: IMPT

Author: Wurz, Marc Christopher

University: Leibniz Universität Hannover

Department: IMPT